

Building Climate Ready Homes

The Where We Build, What We Build Project

This project aims to encourage building or retrofitting of homes that are climate-ready, by demonstrating that the benefits of doing so outweigh the costs.

The Where We Build, What We Build project was undertaken in the Adelaide Hills and Fleurieu Peninsula region. One of the goals of the region is to remain liveable, affordable and resilient in the changing climate, by better managing climate risks.

The project is an initiative of Resilient Hills & Coasts, delivered by Edge Environment. It was jointly funded by the Commonwealth and South Australian Governments under the South Australian Disaster Resilience Grant Program, and the Insurance Council of Australia.

The benefits of building or retrofitting a home to be climate ready outweigh the costs. This climate ready home specification will provide increased resilience against flood, bushfire and extreme heat compared with traditional houses.

Why increase the resilience of a home?

Baseline building compliance is inadequate to ensure a home is climate resilient. Housing is often poorly sited, designed and constructed to account for flood, bushfire and extreme heat.

Vulnerable housing imposes higher living costs and reduces community resilience. It can attract higher insurance premiums and energy bills and have reduced thermal comfort.

For example, the economic analysis shows that building a Climate Ready Home instead of a Contemporary Home will save over \$36,000. By retrofitting a Lightweight 50s House, homeowners can realise benefits valued at up to \$76,000. This includes upfront, maintenance and operational costs, insurance savings and reduced disruption.

Construction vulnerabilities

Materials - current residential designs do not always consider the resilience of materials.

Assembly - current assembly of building elements do not always consider high exposure to more than one hazard and assembly methods for one hazard may be incompatible with other hazards.

Examples of construction vulnerabilities:

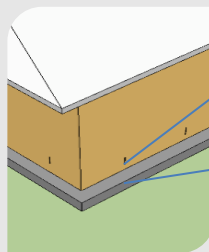

- Inadequate ventilation of wall cavities can lead to deterioration and mould growth; however, gap openings more than 1.8mm can allow ember entry.

- A concrete slab on ground is preferred for bushfire, while for flooding a raised slab is preferred.

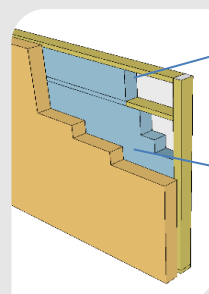

- Fibre cement is recommended when retrofitting wall cladding. Flooding can damage fibre cement. However, replacement costs can be reduced with horizontal installation.

- Materials that get damaged in flooding scenarios like glasswool are used as insulation due to lack of material resilience knowledge.

Where we build. What we build.

New homes

This climate ready home specification will provide increased resilience against flood, bushfire and extreme heat compared with traditional houses. It includes the recommended elements and materials for building a new home.

For a fully referenced specification, refer to the Project Report.

* This specification considers riverine flood prone areas, bushfire prone areas (Bushfire Attack Level 40) and extreme heat within the climate zone 6 according to the Australian Building Code Board. This guidance does not address overland flow. Homes exposed to overland flow should ensure all adopted recommendations comply with overland flow requirements. Not all homes may be exposed to all three of these hazards and therefore only those materials relevant to a site's exposure should be considered (refer to Bushfire Attack Level).

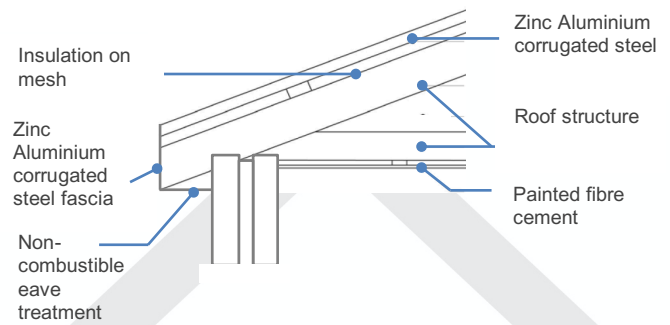
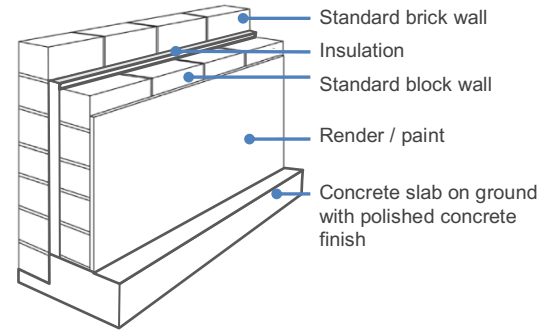

New home elements and materials

Element	Recommended material	Advantages and comments
Ground floor structure	Concrete slab on ground	A concrete slab on ground is not only resilient in a bushfire and flood scenario but also useful for passive design strategies (due to high thermal mass, refer to report for details) to improve resilience to extreme heat.
External wall cladding	Standard brick wall	This material is non-combustible and with best practice assembly it can provide resilience against both bushfire and flood.
Roof covering	Timber framed roof with zinc aluminium corrugated steel in light colours	Provides low ember penetration and is least cost to replace. Light colours allow for a reduction in the thickness of insulation required and will minimise heat externally around the house.
Guttering	Aluminium guttering, sumps and downpipes with bushfire-compliant ember guard	Gutters and leaf guards should be made of non-combustible materials. Gutter leaf guards protect from aggregation of fuel and should have a maximum aperture of 1.8mm to prevent ember attack.

Where we build. What we build.

New home elements and materials

Element	Recommended material	Advantages and comments
Internal linings	Concrete block	Concrete blocks are not damaged when inundated. Extra considerations for inclusion of services such as electrical and communications wiring should be taken into account when using concrete block. Homeowners can choose to render internal walls as well; however, this could increase replacement costs following an inundation scenario.
Wall insulation	Closed cell rigid insulation	Closed cell insulation like XPS and EPS is more resilient to flooding than other options. In relation to bushfire, no ember is considered to enter beyond external materials. However, the following may be taken into account: PIR foam is likely to combust and produce toxic fumes when used in high bushfire risk areas and is therefore not recommended.
Internal wall coverings	Paint	Paint is more resilient and more easily replaced than wallpaper.
Window frame	Aluminium with thermal break	Windows present a risk of breaking and fire penetrating the internal area of a home. The AS3959 standard and the Australian Window Association guidelines for windows in bushfire prone areas should be considered. Thermal breaks reduce heat loss in winter and heat gain in summer.
Window glazing	Double pane window with 6mm exterior toughened glass and bushfire-compliant mesh	These characteristics maximise resilience against the three hazards. In addition, high SHGC, low- U-value and external solar shading on northerly windows is recommended to maximize thermal performance (refer to report for details).
External door	Solid timber door with bushfire-compliant mesh	Flush, solid timber door with BAL40-compliant mesh to increase bushfire resilience rating is recommended. As much bushfire protection as possible is preferred. Steel-wire mesh screens with a maximum aperture of 1.8mm or bushfire shutter prevent ember entry and therefore ignition. Fire resistance characteristics of both the door and mesh (including frame) should be evaluated through testing or certifications guaranteeing resilience against the Bushfire Attack Level (BAL) (refer to report for details).
Floor finishes	Polished concrete	Also useful for passive design strategies (due to high thermal mass, refer to report for details).
Decks, patios and verandas	Concrete slab on ground	Non-combustible materials should be used for all structures to minimise fire spread (includes decking, verandas, fencing and supports).
External rafters and beams or soffits openings protected	Non- combustible materials	Eaves should be lined with a non-combustible material (e.g. steel, fibre cement) to prevent the spread of fire. Passive design strategies to maximise thermal benefits may also be considered.

Where we build. What we build.

Retrofitting

Recommendations for retrofitting a climate ready home differ from those for a new build, due to:

1. Ease of installation alongside existing building elements
2. Differing material costs depending on the type of structure that is being retrofitted

For a fully referenced specification, refer to the Project Report.

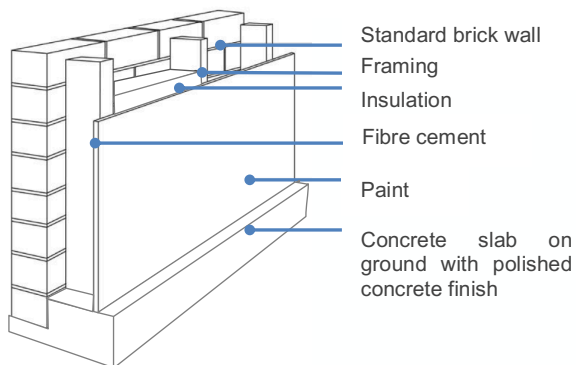

Material variants

Beyond those materials recommended, there may be other suitable materials (variants) that can achieve a similar resilience rating to the hazards in question. To find out more about the resilience of other materials, see the Material Resilience factsheet or Project Report.

Additional considerations

Beyond materials, there are other elements that should be taken into account when designing a climate ready home, including gaps in the building exterior, roof assembly, ground floor structure design, roof and wall system R- value, floor height, structural soundness and continued function of components, Bushfire Attack Level (BAL), siting, proximity to vegetation, water supply and passive design. Refer to the Project Report for more information.

Raising the standard

Substantial research on flood, bushfire and heat resilient building materials exists, but an accepted set of standards has not been fully developed and integrated into planning and building codes. Baseline compliance is currently inadequate to ensure climate resilience.

Lowering insurance premiums

The insurance industry uses hazard maps, and information on construction materials and design, to judge the probability and size of an insurance claim arising from climate hazards. This information is used to set premiums. We can expect insurance premiums to rise in the future, as hazard exposure increases. Examples of this already exist in South Australia. Building a climate resilient home will help to keep insurance premiums low.

Where we build. What we build.

Retrofit elements and materials

Element	Recommended material	Advantages and comments
External wall cladding	Standard brick wall	This material is non-combustible and with best practice assembly it can provide resilience against both bushfire and flood.
Roof covering	Timber framed roof with zinc aluminium corrugated steel and light colours	Provides low ember penetration and is least cost to replace. Light colours allow for a reduction in the thickness of insulation required and will minimise heat externally around the house.
Guttering	Aluminium guttering, sumps and downpipes with bushfire-compliant ember guard	Gutters and leaf guards should be made of non-combustible materials. Gutter leaf guards protect from aggregation of fuel and should have a maximum aperture of 1.8mm to prevent ember attack.
Wall insulation	Closed cell rigid insulation	This material has improved flood resilience. It has a higher melting point than EPS and is therefore preferable in high bushfire risk areas.
Internal wall linings	Fibre cement	Fibre cement sheeting may be easier to install in a retrofit scenario. However, if feasible block or stone should be used to maximise resilience.
Ceiling lining	Fibre cement sheet	Fibre cement sheet is more resilient to flood in an extreme flood situation than other materials. However this recommendation is only relevant to those properties that risk flood heights to a ceiling level.
Windows	Bushfire compliant mesh	A BAL40-compliant mesh can increase bushfire resilience without replacing existing frames and glazing (refer to report for details). Mesh and framing materials should be considered as these can build risk. As much bushfire protection as possible is preferred.
External door	Bushfire compliant mesh	A BAL40-compliant mesh can increase bushfire resilience without replacing existing doors (refer to report for details). As much bushfire protection as possible is preferred.
Ground floor enclosure	Bushfire compliant mesh	For homes with a raised floor structure, it is recommended to enclose the ground floor structure with bushfire-compliant mesh or masonry. Structures built should withstand the forces of floodwater, debris and buoyancy up to and including the 2050 100-year ARI level plus 0.5m.
Roof insulation	Closed cell rigid insulation	A closed cell rigid insulation is more resilient to flood in an extreme flood situation than other materials. However this recommendation is only relevant to those properties that risk flood heights to a ceiling level, which is unlikely in the S&H LGA.
External stairs	Concrete	The use of non-combustible materials like concrete minimize fire spread.